

B-1150.703 Milled in striking plate 21mm

Milled in striking plate with supporting bolts as center striking plate

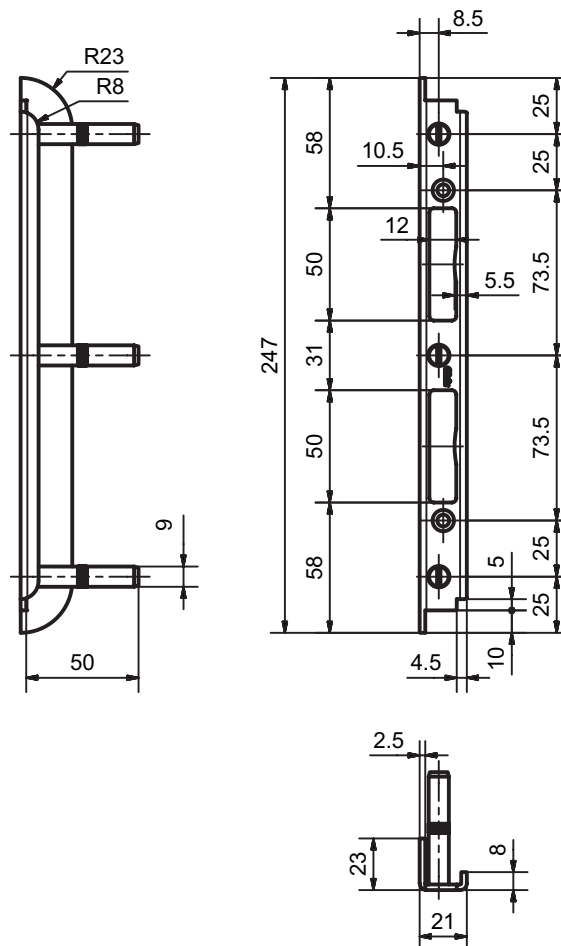

Product profile

High-quality milled in striking plate with supporting bolts, in stainless steel for the mortice locks series 11 and 12 as also for the multipoint locks of the Glutz Treplane family in the versions with distance 78 mm.

Standard version

- X-Dimension (X-Mass): 5.5 mm
- 3 supporting bolts Ø9 x 50 mm
- Distance: 78 mm
- Width: 21 mm
- Length: 247 mm
- Depth: 23 mm
- DIN L and R
- Matt stainless steel: B-1150.703.20

Options

Steel galvanized, blue passivated: B-1150.703.12

Important note

For milling the step milling cutter from HWS Tools® can be used:

- Series 40.100 for routers
- Series 40.150 for CNC machines

As milling jig the MUCK®-striking plate milling jig SBFL32 is recommended.